

This document applies to the following PVC codes

PVC2107	PVC2201	PVC2207	PVC2301
---------	---------	---------	---------

To determine the compatible kit for your platform, complete the following steps:

1. Locate alpha-numeric code located on the swing gate as shown in figure 1 below. If alpha-numeric code:
 - A. Begins with "AA" continue to step 2.
 - B. Does not begin with "AA" order bolt on fall arrest kit 1001237882.
2. Measure the radii on the top corners of the platform (indicated in figure 2).
 - A. If measurement is 3.75 inches (95mm) order bolt on fall arrest kit 1001237882.
 - B. If measurement is 3.00 inches (76mm) order bolt on fall arrest kit 1001302660

Figure 1.

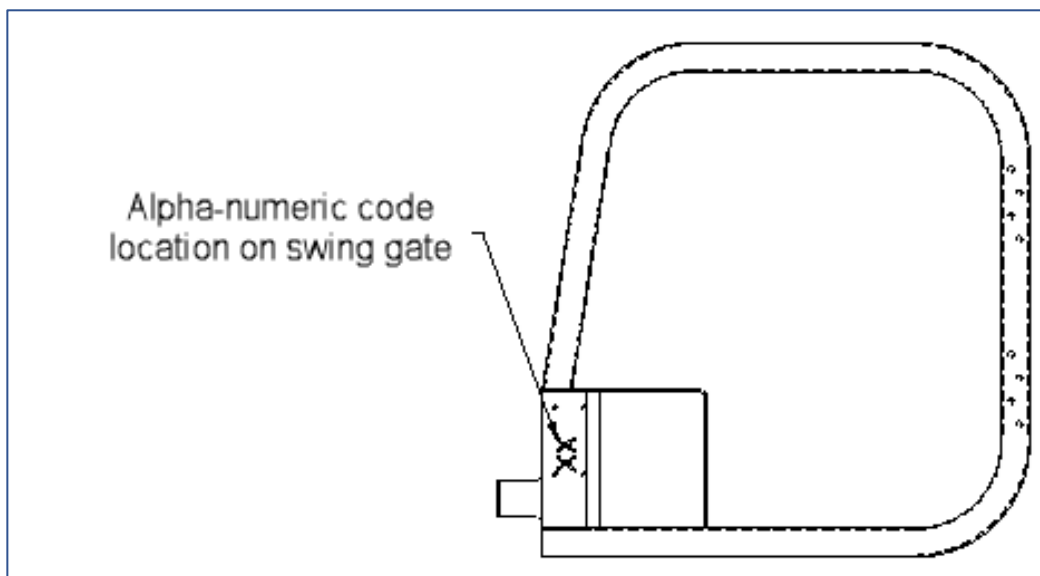

Figure 2.

